

ATON G SWIVEL Infant Car Seat

Owner's Manual

▲ READ this Owner's Manual carefully before first use, and keep it for future reference.

Welcome to CYBEX!

Thank you for purchasing the CYBEX ATON G SWIVEL. We are proud to bring this German-engineered product to the United States and Canada. We hope the ATON G SWIVEL will make your child's travel both safer and more pleasant, as well as make installation and use for you as simple as possible.

Statistics show that over 75% of Child Restraints are being used incorrectly!

Please read and follow these instructions carefully to install the CYBEX ATON G SWIVEL correctly, even if the installation and use of this Infant Car Seat might seem simple and intuitive. Before the first use of the CYBEX ATON G SWIVEL Infant Car Seat, please make sure you have followed all the steps in the Safety Checklist on pg. 78.

Following the American Academy of Pediatrics' recommendations for safe transportation of infants, **we recommend children remain in a REAR-FACING Car Seat as long as possible, until they reach the highest weight or height allowed by their seat.** Visit www.aap.org for more information on the Academy's recommendation.

No Car Seat can guarantee protection from injury in every situation, but proper use helps reduce the risk of death or serious injury. If you have any questions or need assistance, please contact ParentLink Customer Service at 1-877-242-5676 (USA and Canada).

Also, please remember to register your Infant Car Seat so we can contact you in the unlikely event of a recall. Register online at: <http://register.cybex-online.com/us/carseats> (USA) or <http://register.cybex-online.com/ca/carseats> (Canada).

Keep this Owner's Manual for future reference by storing it in the slot at the front of the ATON G SWIVEL Base. We appreciate your purchase and invite you to visit www.cybex-online.com to see other great CYBEX products.

According to the U.S. National Highway Traffic Safety Administration (NHTSA), Car Seats and boosters provide protection for infants and children in a crash, yet car crashes are a leading cause of death for children.

To reduce the risk of **SERIOUS INJURY** or **DEATH**, read this owner's manual and your vehicle owner's manual before installing and using this Car Seat. Using a Car Seat makes a big difference. By properly using this Car Seat and following these instructions, the instructions on the Car Seat, and the instructions that accompany your vehicle, you will greatly reduce the risk of serious injury or death to your child from a crash. Do not be misled by the commonly used term "safety seat"; no Restraint system can prevent all injuries in all crashes. Many properly restrained adults and children are injured in motor vehicle crashes, including relatively minor crashes. A properly used Car Seat is the best way to minimize injuries to your child and to increase the chances for your child's survival in most crashes.

Table of Contents

READ OWNER'S MANUAL PRIOR TO INSTALLING AND USING THIS CHILD RESTRAINT. KEEP INSTRUCTIONS FOR FUTURE USE.

Welcome to CYBEX!	2
Registration and Recall Information	6
Child Usage Guidelines	8
Premature Infant Use	10
Warnings	12
Overview of the ATON G Infant Car Seat	22
Overview of the ATON G SWIVEL Base.....	24
Product Features and Descriptions	
Chest Clip	26
Handle Positions.....	26
Harness Adjustment	27
Harness Buckle	27
Infant Insert.....	28
Integrated XXL Canopy	28
No Rethread Harness.....	29
Recline Adjustment.....	30
Rotating Base	32
SafeLock™ Belt Tensioner.....	36
Shoulder Pads	36

Table of Contents

Installing and Removing the Infant Car Seat with the Base	
Installing with Base Using LATCH/UAS	37
Storing LATCH/UAS for Installations with Vehicle Belts.....	42
Installing with Base Using Lap/Shoulder Belts	43
Installing with Base Using Lap Belt Only	48
Installing and Removing the Infant Car Seat ONLY	
Installing the Infant Car Seat with Lap/Shoulder Belts	53
Installing the Infant Car Seat with Lap/Shoulder Belts (Alternate).....	57
Installing the Infant Car Seat with Lap Belt Only	60
Securing the Child	62
Changing the Buckle Strap Position	66
Using the Infant Car Seat on Aircraft.....	68
Removing and Replacing Seat Cover.....	70
Care and Cleaning.....	77
Safety Checklist.....	78
Resources	79
Warranty	80

Registration and Recall Information

REGISTERING YOUR CHILD RESTRAINT

Please complete the registration card that came with your Child Restraint and mail it in immediately or register online.

Child Restraints could be recalled for safety reasons. You must register this Restraint to be reached in a recall. Send your name, address, e-mail address if available, and the Restraint's model number and manufacturing date to:

**Columbus Trading-Partners USA Inc.
Attn: ParentLink Customer Service
1801 Commerce Drive
Piqua, Ohio 45356, USA**

or call 1-877-242-5676 or register online at
[http://register.cybex-online.com/us/
carseats](http://register.cybex-online.com/us/carseats)

For recall information, call the U.S. Government's Vehicle Safety Hotline at: 1-888-327-4236 (TTY: 1-800-424-9153), or go to www.NHTSA.gov.

PUBLIC NOTICE FOR CANADIAN CUSTOMERS

Child Restraints could be recalled for safety reasons. To register your Child Restraint, return the registration card, call Goodbaby Canada Inc. at 1-877-242-5676, or register online at <http://register.cybex-online.com/ca/carseats>

For recall information, call Transport Canada at 1-800-333-0510 (1-613-993-9851 in Ottawa region) or Goodbaby Canada Inc. at 1-877-242-5676, or go to www.tc.canada.ca.

For public notice information, call Transport Canada at 1-800-333-0510 (1-613-993-9851 in Ottawa region).

Registration and Recall Information

CERTIFICATION

Regulatory Notice: This Child Restraint system meets all applicable requirements of Federal Motor Vehicle Safety Standard (FMVSS) 213 and Canadian Motor Vehicle Safety Standards (CMVSS) 213 and 213.1.

This Restraint is certified for use only in passenger and multi-purpose passenger motor vehicles, buses, and trucks equipped with Lap/Shoulder Belt systems.

THIS RESTRAINT IS CERTIFIED FOR USE IN AIRCRAFT IF USED WITHOUT THE BASE.

Check with your airline before departure to make sure this Restraint meets their requirements, then refer to pgs. 68-69 for complete instructions on installing your Child Restraint in aircraft.



Child Usage Guidelines

! WARNING! DEATH or SERIOUS INJURY can occur.

This Child Restraint is designed for use by children in **REAR-FACING MODE ONLY**. To use this Child Restraint properly, children **MUST** meet the size and age requirements on the following pages.

The American Academy of Pediatrics (AAP) recommends keeping children **REAR-FACING** for as long as possible, until they reach the maximum height or weight for their Child Restraint in **REAR-FACING** orientation.* Additionally, some states' laws require children to be **REAR-FACING** until age 2. Accordingly, you will see this guidance reflected in the Child Requirements on the following pages. Please review any applicable local, state or provincial laws related to child passenger safety before installing and using this Child Restraint.

Child Usage Guidelines

Do not use this Child Restraint if your child does not meet all of these requirements:

- Weight is between 1.8 and 15.8 kg (4 and 35 lbs)
- Height is between 43 and 81 cm (17 and 32 in)
- Top of child's head is a minimum of 2.5 cm (1 in) below the top of the Infant Car Seat or Headrest, **WHICHEVER IS HIGHER.**

IMPORTANT: Once your child **EXCEEDS** any of the size requirements above, they **MUST DISCONTINUE** use of this Child Restraint. After your child outgrows the ATON G SWIVEL, keep your child **REAR-FACING** in a convertible or all-in-one Car Seat as long as the seat allows, according to the manufacturer's specifications, before turning them around to ride **FORWARD-FACING**.

IMPORTANT: For proper use of the Infant Car Seat, the Harness Straps **MUST** be **AT OR JUST BELOW** your child's shoulders.

NOTE: Regularly check for proper Harness height as your child grows.

Minimum 2.5 cm
(1 in)

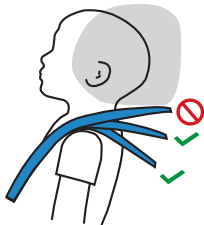

Child Usage Guidelines

Premature Infant Use

Before using this Child Restraint for preterm or low birth weight infants, ensure the Child Requirements are met and follow the guidelines in this section.

According to the National Highway Traffic Safety Administration (NHTSA), a properly installed Child Restraint reduces the risk of death by over 70% for infants involved in crashes. Federal Motor Vehicle Safety Standard (FMVSS) 213 establishes design and dynamic performance requirements for Child Restraint systems. However, the standard has no minimum weight limit and does not address the special medical needs of preterm or low birth weight infants. To ensure that preterm and low birth weight infants are transported safely, the guidelines published by the American Academy of Pediatrics (AAP) in Pediatrics 2009;123:1424–1429 (reaffirmed June 2018) must be followed.

Preterm and low birth weight infants are at additional risk of breathing difficulties and heart problems when placed in a Child Restraint. CYBEX requires that the evaluation recommended by the AAP be conducted for all infants born earlier than 37 weeks and all newborn infants who weigh less than 2.26 kg (5 lbs) at birth before their first car trip to check for breathing difficulties or heart rate problems when traveling in a **REAR-FACING** Child Restraint. Newborn infants should **NEVER** travel in a **FORWARD-FACING** Child Restraint.

The AAP recommends that appropriate hospital staff observe your infant in the Child Restraint for a period of 90 to 120 minutes or the duration of travel, whichever is longer. This period of observation must be performed with the infant properly positioned as described in these instructions and with the Child Restraint placed at an angle that is approved for use in the vehicle. The hospital staff will check for any breathing difficulties or heart rate problems. Your child's pediatrician will let you know if there are any special

Child Usage Guidelines

Premature Infant Use

considerations for travel. The number of trips and the duration of time the infant is seated in the Child Restraint should be minimized. A caregiver should ride in the back seat to monitor the infant during travel.

You can learn more about the AAP's recommendations as well as other resources for parents and medical professionals, at <https://www.healthychildren.org/english/safety-prevention/on-the-go/Pages/default.aspx>.

Routing the Harness Buckle for Use with Premature and Smaller Infants

1. Partially remove the Seat Cover from the front of the seat.
2. From the top of the seat, feed the Buckle Strap Anchor and Harness Buckle Cover through the rear slot in the Seat Cover.
3. Feed the Buckle Strap Anchor through the rear slot and then from underneath the seat, feed the Buckle Strap Anchor up through the middle slot, making sure it goes completely through the slot and lays flat against the bottom of the seat.
4. Replace the Seat Cover.
5. See pages 66-67 for more information.

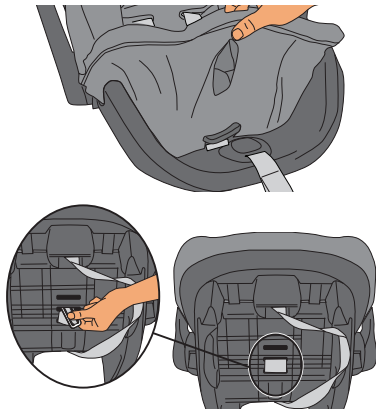

! WARNING! DEATH or SERIOUS INJURY can occur.

AIRBAG WARNINGS

- **DO NOT** place a **REAR-FACING** Child Restraint on a front seat with an active airbag. **DEATH OR SERIOUS INJURY** can occur. The back seat is the safest place for children 12 and under.
- **DO NOT** use this Restraint in the front seat of a vehicle equipped with an air bag. Interaction between a rear facing Restraint and air bags may cause death or serious injury. If your vehicle has an air bag, refer to the vehicle owner's manual for Child Restraint installation.
- **DO NOT** use this Restraint in a vehicle seating position equipped with a side air bag unless authorized by the vehicle manufacturer. Refer to vehicle owner's manual.



- **DO NOT** place any objects between the Restraint and the side air bag, as an expanding air bag may cause the items to strike your child.

GENERAL WARNINGS

The primary protection for occupants of a vehicle in a collision is the structure of the vehicle itself. Correctly used per the instructions and labeling, this Child Restraint will substantially improve the chances for survival in most crashes.

- **READ** this Owner's Manual carefully before first use and keep it for future reference.
- **FOLLOW ALL INSTRUCTIONS** on this Infant Car Seat and in the written instructions stored in the slot at the front of the ATON G SWIVEL Base.

WARNING! DEATH or **SERIOUS INJURY** can occur.

- **NEVER** install or use this Child Restraint until you have read and understand the instructions in this manual, your vehicle owner's manual, and the labels on your Infant Car Seat. If there is a conflict between this manual and the vehicle owner's manual, the vehicle owner's manual must be followed. Failure to follow these instructions can result in death or serious injury to your child in a crash.
- **DO NOT** allow others to install or use this Child Restraint unless they understand how to correctly install and use it.
- **NEVER** allow someone else to use this Child Restraint without also passing along this manual to them.
- **DO NOT** use a Child Restraint with an unknown history.
- **NEVER USE CHILD RESTRAINT IF IT HAS DAMAGED, BROKEN, OR MISSING PARTS.**
- **DO NOT** attempt to make repairs to or otherwise modify or tamper with this Child Restraint.
- **ALWAYS REPLACE THE CHILD RESTRAINT AFTER A CRASH OF ANY KIND, EVEN IF IT WAS UNOCCUPIED.** A crash can cause damage to the Child Restraint that may not be visible.
- **ALWAYS** check Buckles and other parts for hot surfaces before placing your child in the Child Restraint. A hot surface could burn your child! Cover an unoccupied Child Restraint with a blanket when leaving it in a vehicle. The interior of a vehicle can become hot enough to burn child even on a cloudy day.

LOCATION WARNINGS

- **ACCORDING TO ACCIDENT STATISTICS**, children are safer when properly restrained in rear vehicle seating positions.

! WARNING! DEATH or SERIOUS INJURY can occur.

- **ONLY** place this Child Restraint in a vehicle seating location allowed by the vehicle manufacturer. To determine allowable seating positions, refer to your vehicle owner's manual for information about vehicle seat belt systems, air bags, side air bags, front passenger side air bags and Child Restraint installations.
- **NOT EVERY LOCATION WITHIN A VEHICLE MAY BE SAFE FOR THE INSTALLATION OF THIS CHILD RESTRAINT.** In fact, some vehicles have no seating position that is safe for the installation of this Child Restraint. Improper placement of this Child Restraint within a vehicle will increase the risk of death or serious injury.
- **NEVER** use this Child Restraint in a vehicle seating position where it cannot be secured tightly. A loosely installed Child Restraint will not protect your child in a crash.

- **ONLY** use this Child Restraint on **FORWARD-FACING** vehicle seats.
- **NEVER** install this Child Restraint in vehicle seats that face the rear or side of the vehicle.



- **VEHICLE TYPES WHERE THE RESTRAINT SYSTEM CAN NOT BE USED:** This Child Restraint is **NOT** to be used in vehicles that do not have vehicle seat belts or lower anchors (see pgs. 17-19).
- **ONLY** use this Child Restraint on vehicle seats with backs that lock into place. In the event of a sudden stop, an unlocked vehicle seat back could prevent this Child Restraint from protecting your child.

WARNING! DEATH or **SERIOUS INJURY** can occur.

- **NEVER** use this Child Restraint on boats, low speed vehicles (LSV), all-terrain vehicles (ATV), golf carts, or any other non-certified application.
- Children have **STRANGLED** in loose or partially buckled Harness Straps. **FULLY RESTRAIN** the child even when the Carrier is used outside the vehicle.

USAGE WARNINGS

- **ONLY USE** with children who weigh between 1.8 and 15.8 kg (4 and 35 lbs) **AND** whose height between 43 and 81 cm (17 and 32 in).
- **DO NOT USE** this Child Restraint if top of child's head is less than 2.5 cm (1 in) below the top of the Infant Car Seat or Headrest, **WHICHEVER IS HIGHER**.
- **ONLY USE** this Child Restraint **REAR FACING**.
- **ONLY USE** this Child Restraint with the Base secured in the Drive Position.
- **ALWAYS USE** the complete and buckled five-point Harness around your child.
- **ALWAYS CHECK** the Harness Buckle to make sure it is securely latched.
- **ALWAYS** have the Handle in a **LOCKED** position while using this Child Restraint in a vehicle (see pg. 26).
- **ALWAYS** have the Handle **LOCKED** in the CARRY Position when lifting by the Handle. Lifting from **ANY OTHER LOCKED** or **UNLOCKED** Position could cause the child to fall.
- **ALWAYS CHECK** to make sure the Infant Car Seat is securely attached to the Base each time you use this Restraint. After attaching the Infant Car Seat to the Base, **LIFT UP** on the Handle to ensure the Carrier is securely attached to the Base.

! WARNING! DEATH or **SERIOUS INJURY** can occur.

- **BEFORE** each use, **ALWAYS CHECK** that the Child Restraint is tightly secured in the vehicle seat and does not move more than 2.5 cm (1 in) in any direction when checked at the Belt Path.
- **WHEN NOT IN USE**, securely store LATCH/UAS Connectors.
- **NEVER** allow children to play with the SafeLock Belt Tensioner (pg. 36).
- **SUFFOCATION HAZARD:** Infant Car Seat can roll over on soft surfaces and suffocate child. **NEVER** place Infant Car Seat on beds, sofas, or other soft surfaces.
- **FALL HAZARD:** Child's activity can move Carrier. **NEVER** place Carrier on counter tops, tables, or any other elevated surfaces.

- **FALL HAZARD:** The Carrier can fall from the shopping cart. Do not use on shopping cart.
- **ONLY USE** Infant Car Seat with strollers that are approved by CYBEX. Refer to the stroller Owner's Manual for details about how to attach the Infant Car Seat to your stroller. For a list of compatible strollers, please visit www.cybex-online.com.



ADDITIONAL WARNINGS

- **REGISTER** your Child Restraint with the manufacturer. This is the best way to reach you in the event of a recall.
- **NEVER USE** this Child Restraint when it is older than six (6) years. The date of manufacture can be found on a label affixed to the bottom of the Infant Car Seat, as well as on the Base.

! WARNING! DEATH or SERIOUS INJURY can occur.

- **NEVER USE** this Child Restraint if the Harness Straps are cut, frayed, or damaged in any way.
- **NEVER LEAVE** child unattended.
- **NEVER USE** accessories or parts with this Child Restraint other than those approved by CYBEX. Use of accessories or parts from other manufacturers could alter the performance of the Child Restraint.
- **DO NOT** attach additional padding, toys, or other devices not made by CYBEX or described in these instructions for the Child Restraint. Items not tested with the Child Restraint could injure the child. Additional pads or pillows may interfere with the function of the Harness system, or cause breathing problems if the child's head falls forward, increasing the risk of serious injury or death.

SEAT BELT WARNINGS

- **ALWAYS** read your vehicle owner's manual to determine what vehicle belts and retractors are used in your vehicle.

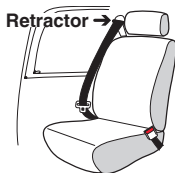

- **DO NOT** use this Child Restraint in a seating position with door-mounted seat belts.



- **DO NOT** use this Child Restraint in a vehicle with seat belts that automatically move along the vehicle frame when the door is opened.

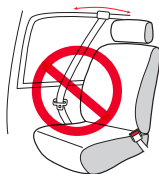

! WARNING! DEATH or SERIOUS INJURY can occur.

- **DO NOT** use this Child Restraint in a vehicle equipped with Lap Belts that only lock during a sudden stop or crash (Emergency Locking Retractor - ELR). You must use a seating location with a Lap/Shoulder Belt or a locking Lap Belt. Check your vehicle owner's manual to see if you have Lap Belts with ELRs.



- **DO NOT** use on vehicle seats when both portions of the lap-only belt are positioned forward of the seat crease.



- **DO NOT** use with Lap/Shoulder Belts with two retractors. If the vehicle seat belts are not routed and fastened correctly, the Child Restraint may not protect the child in a crash.



- **DO NOT** use this Child Restraint with inflatable seat belts.
- Check your vehicle owner's manual to determine how to lock your seat belt for Child Restraint installation. The seat belt **MUST** be locked to properly secure the Child Restraint.
- **DO NOT** allow the vehicle seat belt release button to touch the Child Restraint. Accidental contact may cause the seat belt to release. If necessary, turn the seat belt release button away from the Child Restraint or move the Child Restraint to a different location.
- Child Restraint systems should be securely belted to the vehicle, **even when they are not occupied**, since in a crash an unsecured Child Restraint system may injure other occupants.

! WARNING! DEATH or SERIOUS INJURY can occur.

If you have any of these types of vehicle belt systems listed, these are SAFE to use to install your Child Restraint in the vehicle. Review vehicle owner's manual for specific instructions on Child Restraint installation.

Lap Belt with Locking Latch Plate

- Once buckled, the vehicle belt is tightened by pulling on the free end of the strap until the belt is tight.

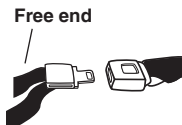

Lap/Shoulder Belt with Locking Latch Plate

- The lap portion of this belt does not loosen once the belt is buckled.
- The vehicle belt is tightened by pulling up hard on Shoulder Belt and feeding the extra webbing into the retractor.

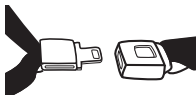

Lap Belt with Automatic Locking Retractor (ALR)

- The automatic locking retractor does not allow the Lap Belt to get longer once it is buckled. The vehicle belt is tightened by feeding seat belt webbing into retractor.

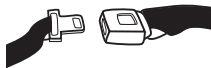

Lap/Shoulder Belt with Sliding Latch Plate with Locking Retractor

- The latch plate slides freely along the Lap/Shoulder Belt. Vehicle belts with sliding latch plates are typically locked at the Shoulder Belt Retractor by buckling the belt and pulling all of the webbing out slowly to switch the retractor.
- Check vehicle owner's manual for specific instructions. The vehicle belt is tightened after switching the retractor by pulling up on Shoulder Belt and feeding the webbing into the retractor.

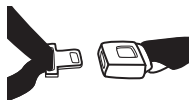

! WARNING! DEATH or SERIOUS INJURY can occur.

LATCH and **UAS** are acronyms for **Lower Anchors** and **Tethers for Children (USA)** and **Universal Anchorage System (Canada)**, and refer to a pair of fixed Lower Anchors (or bars) and a Top Tether Anchor that are built into your vehicle, in vehicles built after September 1, 2002. Your vehicle owner's manual may also refer to this system as **ISOFIX** or **Lower Universal Anchorage System (LUAS)**.

The lower LATCH/UAS Anchors are located in the crease, or bight, between the vehicle seat back and seat cushion, and if not visible, will typically be indicated by the  symbol. Top Tether Anchors are located in various places behind the rear vehicle seat.

Center Seating Positions. CYBEX allows this Child Restraint to be installed using the two inner Lower Anchors from the outboard seating positions if (1) your vehicle owner's manual allows such an installation; and (2) the distance between the inner Lower Anchors is 28-51 cm (11-20 in). When using the inner Lower Anchors make sure there are no obstructions from a Buckle Stalk for the installation or that the LATCH/UAS Connectors do not block vehicle belt buckles.

This Child Restraint can be safely installed using either LATCH/UAS or vehicle belts and meets the requirements of Federal Safety Standard FMVSS 213 and Canadian Safety Standard CMVSS 213 with either installation method. Either method is safe for your child when installed correctly.

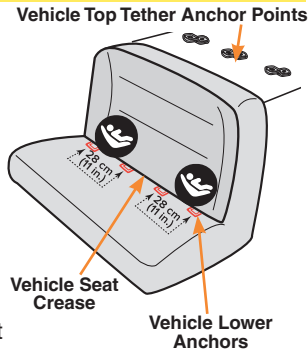

! WARNING! DEATH or SERIOUS INJURY can occur.

- The LATCH/UAS System is intended to be used **ONLY** as described in these instructions. Refer to your vehicle owner's manual for lower anchor bar positions in your vehicle.
- In addition to these instructions, read and follow your vehicle owner's manual regarding installation of the Child Restraint and LATCH/UAS. If there is a discrepancy, follow your vehicle owner's manual.
- **DO NOT** install this Child Restraint with LATCH/UAS and the vehicle's seat belts at the same time.
- **ONLY** use for securing Child Restraint to vehicle lower anchor bars.
- **NEVER** attach two LATCH/UAS Connectors to one vehicle lower anchor bar.
- **ALWAYS** be sure that LATCH/UAS is attached to the vehicle lower anchor bars by pulling hard on the Lower Anchor Connectors. If they are not attached, the Lower Anchor Connector assembly will not secure your Child Restraint.

Overview of the ATON G Infant Car Seat

Front Side

1. Handle
2. Seat Cover
3. Lap Belt Guides
4. Flip-Forward Buckle Pad
5. Harness Adjustment Button
6. Harness Adjustment Strap
7. No Rethread Harness Adjuster Handle
8. Headrest
9. Shoulder Pads
10. Chest Clip
11. Harness
12. Harness Buckle
13. Canopy
14. Infant Insert

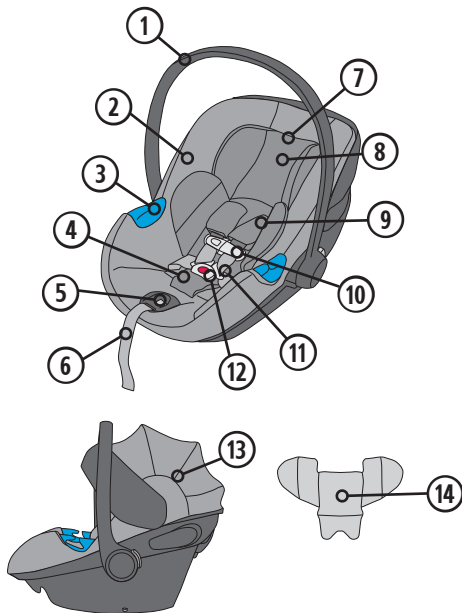

Overview of the ATON G Infant Car Seat

Back Side

- 15. Buckle Strap Anchor
- 16. Base Attachment Hooks
- 17. Shoulder Belt Guide
- 18. Carrier Release Handle
- 19. Handle Adjustment Button

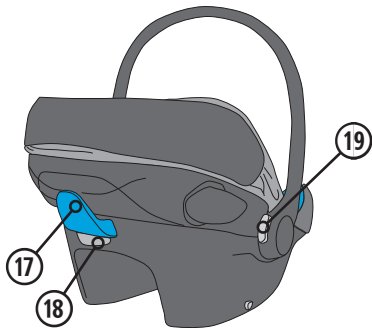
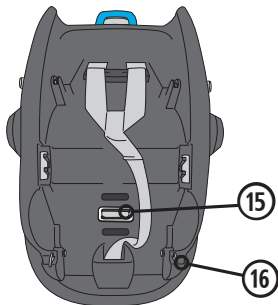

Overview of the ATON G SWIVEL Base

1. Recline Adjustment Handle
2. Adapter
3. Carrier Attachment Bars
4. SafeLock Belt Tensioner
5. Belt Tensioner Release Button
6. LATCH/UAS Connector
7. LATCH/UAS Adjuster
8. LATCH/UAS Strap
9. Swivel Handle
10. Owner's Manual Storage Compartment

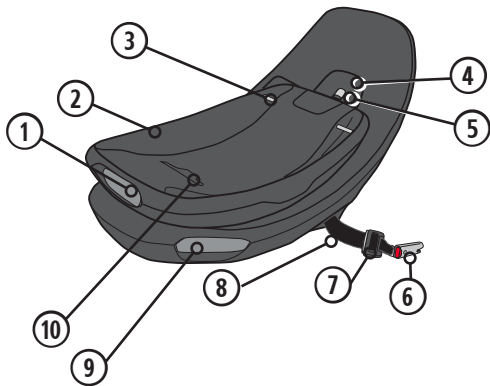

Overview of the ATON G SWIVEL Base

11. LATCH/UAS Storage Slots

12. Recline Indicators

13. Belt Path Opening

14. Belt Path

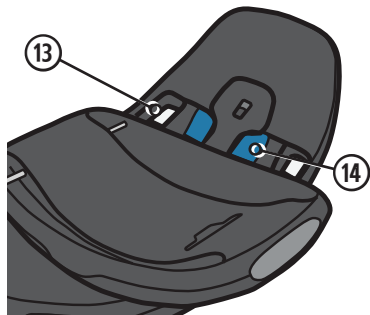
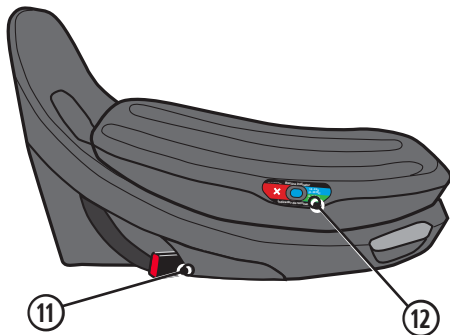

Product Features and Descriptions

Chest Clip

To separate Chest Clip, push button and pull apart. To fasten, slide the two pieces together until an audible **CLICK** is heard.

Always position the center of the Chest Clip even with the child's armpits.

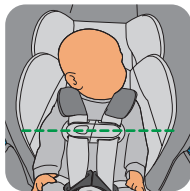
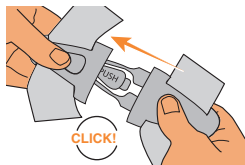

Handle Positions

! WARNING! DEATH or SERIOUS INJURY can occur.

ALWAYS have the Handle in a **LOCKED** position while using this Child Restraint in a vehicle.

The Handle has four **LOCKED** positions:

1. Carry
2. Intermediate
3. Intermediate
4. Resting

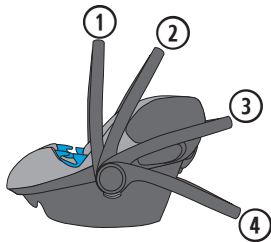

To rotate the Handle, squeeze BOTH Handle Adjustment Buttons **A** at the same time while moving the Handle **B** between positions.

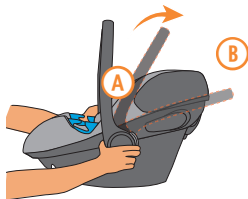

Product Features and Descriptions

Harness Adjustment

Loosen Harness by firmly pressing down the Harness Adjustment Button **A** while pulling forward on both straps **B** at shoulder level. Pull the Adjuster Strap **C** to tighten the Shoulder Straps.

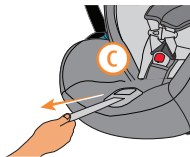
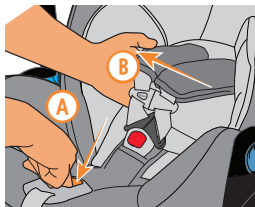

Harness Buckle

To release Buckle Tongues, firmly press the red button on the Harness Buckle and pull the tongues out.

To fasten, insert each Tongue into Buckle, listening for an audible **CLICK**. Pull on each to verify a secure connection.

Check that the Buckle functions properly and is kept free of dirt and debris. For cleaning, see pg. 77.

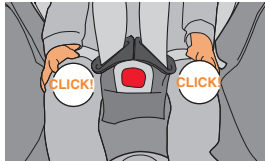
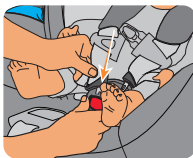

Product Features and Descriptions

Infant Insert

The optional Infant Insert will help provide a better Harness fit for smaller babies, as well as stability for the torso.

We recommend using the Infant Insert until about 3 months of age or the baby weighs about 5 kg (11 lbs). When installed, the Insert should be flush with the Buckle as shown.

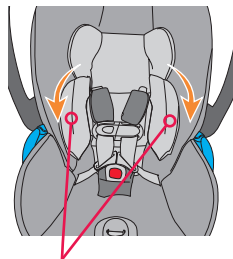
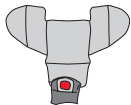

Foldable Side Wings

When used with a smaller child, the Infant Insert Side Wings can be folded in for better support of the child and to help with proper fit when securing the child (see pgs. 62-65).

Integrated XXL Canopy

The Integrated XXL Canopy has four positions. Simply pull forward to extend and gently push back to retract the Canopy into its original position.



Product Features and Descriptions

No Rethread Harness

The ATON G SWIVEL has a Headrest that automatically adjusts the Harness height without the need to undo and rethread the Harness. Using the seat's No Rethread Harness, the Headrest may be adjusted up and down through 12 positions to fit your baby.

The ATON G SWIVEL is shipped in the lowest position with the Infant Insert (pg. 28) already in position.

1. Unbuckle the Harness and Chest Clip, then drape the Harness over the sides of the Infant Car Seat Shell.
2. Place the child in the Infant Car Seat, making sure their back and bottom are flush with the Car Seat and the Buckle Strap is snug against the child but NOT under the child's bottom.
3. Adjust for your baby by pulling up on the No Rethread Harness Adjuster Handle (A) while sliding the Headrest up until the Harness Slots are even with or slightly below your child's shoulders.

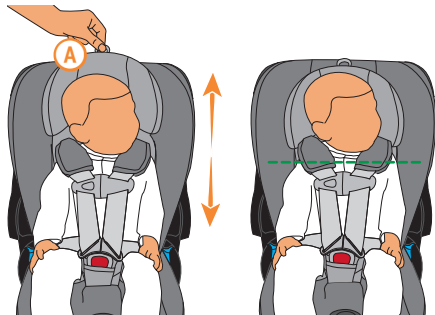

IMPORTANT: For proper use of the Infant Car Seat, the Harness Straps **MUST** be **AT OR JUST BELOW** your child's shoulders (see pg. 9).

4. Buckle and snug Harness.

NOTE: Regularly check for proper Harness height as your child grows.

Product Features and Descriptions

Recline Adjustment

! WARNING! DEATH or SERIOUS INJURY can occur.

- It is very important for your child's safety that this Child Restraint be installed at the correct recline angle. Failure to properly recline the Child Restraint on the vehicle seat increases the risk of **DEATH OR SERIOUS INJURY**.
- **DO NOT** use this or any other Child Restraint with a premature, low birth weight, or medically fragile infant, until after you have consulted with your doctor. Some infants may have difficulty breathing or have other medical problems when placed in a seated position.
- If the Child Restraint is **TOO UPRIGHT**, the child's head may fall forward and cause breathing problems. If the Child Restraint is **TOO RECLINED** crash protection will be reduced.

INFANT CAR SEAT ONLY

Adjust seat angle until **WHITE LEVEL LINE** on Infant Car Seat is level with the ground.

If you are having trouble achieving the proper recline angle:

1. Uninstall Infant Car Seat.
2. Place a tightly rolled towel or pool noodle under the Infant Car Seat, near the vehicle seat back, as indicated by the green circle.

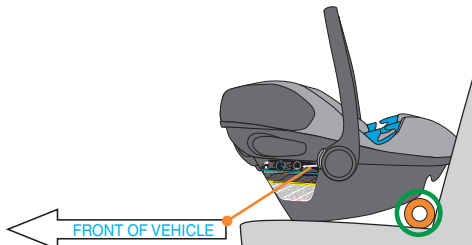

White line **MUST** be parallel to ground when seat is installed in vehicle without base

Product Features and Descriptions

Recline Adjustment

INFANT CAR SEAT WITH BASE:

With the Base and Infant Car Seat installed, and the Base in the Drive Position (see pg. 33):

1. Using the Recline Adjustment Handle (see pg. 24), adjust the Adapter recline angle to one of the three recline positions to achieve the correct angle for your child's weight as shown on the Level Indicator below.

- **BLUE** zone:
1.8 - 9 kg
(4 - 20 lbs)
- **GREEN** zone:
9 - 15.8 kg
(20 - 35 lbs)

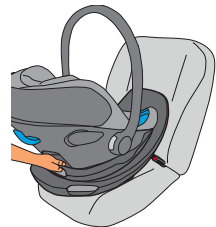

2. Release Recline Adjustment Handle to lock Adapter in place.

Be sure to recheck the recline angle with the child secured in place (see pgs. 62-65).

If Recline Angle is not correct after installation:

- Readjust using Recline Adjustment Handle, **or**
- Use a tightly rolled towel or pool noodle under the Base, near the vehicle seat back, as shown below.

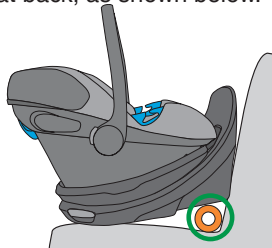

Product Features and Descriptions

Rotating Base

⚠ WARNING! DEATH or SERIOUS INJURY can occur.

- **NEVER** use this Child Restraint in a vehicle seating position where it cannot be secured tightly. A loosely installed Child Restraint will not protect your child in a crash.
- **THE BOARDING POSITION IS FOR LOADING AND UNLOADING YOUR CHILD ONLY!**
- **ONLY USE** this Child Restraint with the Base secured in the Drive Position. The Aton G Swivel is not designed to protect your child in a crash when the seat is not locked in the Drive Position.

The Aton G Swivel rotates in its Base, making it easy to safely load and unload your child from either side of the vehicle when the seat is properly installed.

To rotate the Aton G Swivel, pull the Swivel Handle and turn the Restraint toward the vehicle door until it reaches the Boarding Position (pg. 33).

When your child is securely harnessed, rotate the Restraint away from the vehicle door until you hear an audible **CLICK** that



Product Features and Descriptions

Rotating Base

indicates the Restraint is locked in the Drive Position and can neither rotate nor change recline position.

Verify that the two white lines on the front of the Base are properly aligned.

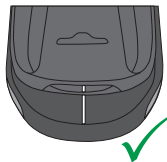

If not, and the "Install Car Seat on Base" label is visible as shown at right, **DO NOT DRIVE** until the seat is positioned correctly.

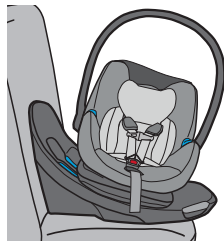

Boarding Position

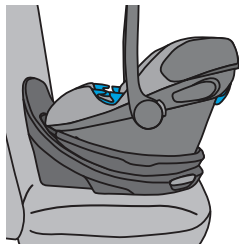

Drive Position

Product Features and Descriptions

Rotating Base

! WARNING! DEATH or SERIOUS INJURY can occur.

ALWAYS have the Handle **LOCKED** in the **CARRY** Position when lifting by the Handle. Lifting from **ANY OTHER LOCKED** or **UNLOCKED** Position could cause the child to fall.

PLACING THE INFANT CAR SEAT ON THE BASE

1. Make sure Handle is locked in **CARRY POSITION** (see pg. 26).

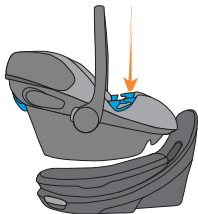

2. Pick up Infant Car Seat by Handle and install onto Base. An audible **CLICK** is heard.

NOTE: To rotate the Base to the Boarding Position, see pgs. 32-33.



3. Lift up on the Infant Car Seat to ensure it is secured to the Base.

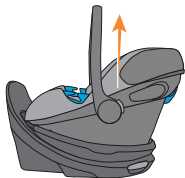

Product Features and Descriptions

Rotating Base

! WARNING! DEATH or SERIOUS INJURY can occur.

ALWAYS have the Handle **LOCKED** in the CARRY Position when lifting by the Handle. Lifting from **ANY OTHER LOCKED** or **UNLOCKED** Position could cause the child to fall.

REMOVING THE INFANT CAR SEAT FROM THE BASE

1. Squeeze the Carrier Release Handle.

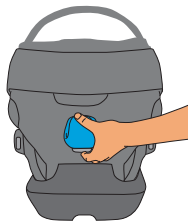

2. Lift the Carrier up off the Base.

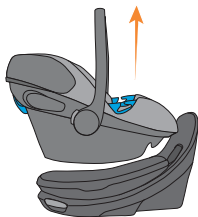

Product Features and Descriptions

SafeLock™ Belt Tensioner

The ATON G SWIVEL Infant Car Seat Base is equipped with a SafeLock Belt Tensioner that achieves a quick and secure installation when using lower anchors, Lap/Shoulder, or Lap only vehicle belts.

To Open the SafeLock Belt Tensioner, rotate Adapter to Boarding Position and push button on Belt Tensioner Handle and pull open.

To Close, press down on the sides of the SafeLock Belt Tensioner until an audible **CLICK** is heard.

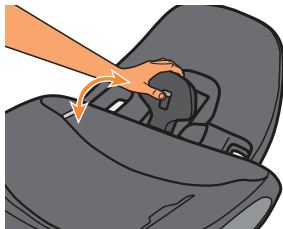

Shoulder Pads

The optional Shoulder Pads may be used for added comfort. Wrap Shoulder Pads around Harness Straps and snap closed as shown. Always check that the Shoulder Pads **DO NOT** bunch up when tightening the Harness.

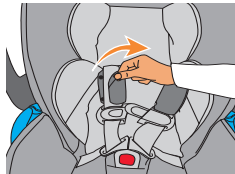

Installing and Removing the Infant Car Seat with the Base

Installing with Base Using LATCH/UAS

1. Remove LATCH/UAS Connectors from storage locations on back side of Base. Remove each connector by pushing the red button while pulling out.



2. Make sure the vehicle is on level ground and place the Base in an approved vehicle seating location.

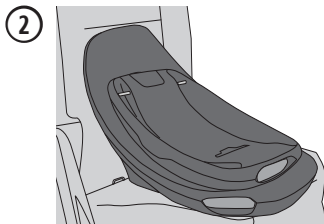

Installing and Removing the Infant Car Seat with the Base

Installing with Base Using LATCH/UAS

3. Rotate Adapter to Boarding Position (see pgs. 32-33) and, while holding the Base with one hand, push button on Belt Tensioner Handle and pull open.
4. Extend the LATCH/UAS Straps to their longest length, making sure the belt lies flat and is not twisted.
5. Push the LATCH/UAS Connectors onto the vehicle lower anchor bars on both sides of the Base until you hear them **CLICK**, then **CHECK** to make sure they are securely attached by pulling on them.

NOTE: For installations where vehicle lower anchors may be difficult to reach, you may obtain LATCH/UAS Guides by calling ParentLink Customer Service at 1-877-242-5676.

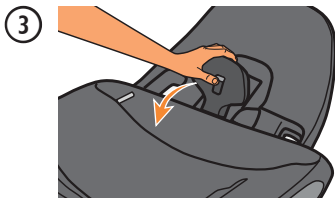

Installing and Removing the Infant Car Seat with the Base

Installing with Base Using LATCH/UAS

6. Pull LATCH/UAS Adjustment Strap while pushing Base tight against the seat. Remove all slack from the strap, being careful not to overtighten, then lay the free end across the Belt Path. The SafeLock Belt Tensioner will tighten the system fully.

6



7. Press down on the sides of the SafeLock Belt Tensioner until an audible **CLICK** is heard. If Belt Tensioner does not lock, try loosening the LATCH/UAS Strap slightly, then try to close again.

7



Installing and Removing the Infant Car Seat with the Base

Installing with Base Using LATCH/UAS

8. Grab the Base at the Belt Path and pull from side to side and front to back to make sure it is installed correctly. The Base should not move more than 2.5 cm (1 in) in any direction.

If the Base moves too much, open the SafeLock Belt Tensioner and remove a little more slack from the LATCH/UAS Strap, then close and recheck. After this, if the Base still moves too much, you may need to try a different vehicle seat location or installation method, or both.

9. Place the Infant Car Seat into the Base, and listen for a **CLICK**. Check that the Car Seat is installed by lifting up on the Handle (see pg. 34).

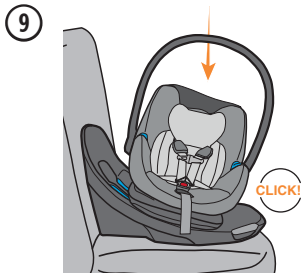
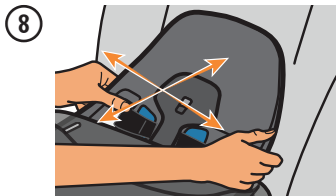

Installing and Removing the Infant Car Seat with the Base

Installing with Base Using LATCH/UAS

10. Rotate Base to Drive Position (see pgs. 32-33).

NOTE: This Child Restraint is allowed to touch the vehicle seat in front of it as long as the recline angle of the Child Restraint is not affected.

10

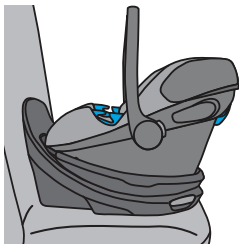

11. Adjust the Adapter recline angle (see pg. 35) to achieve the correct angle for your child's weight as shown on the Level Indicator below.

- **BLUE** zone:
1.8 - 9 kg
(4 - 20 lbs)
- **GREEN** zone:
9 - 15.8 kg
(20 - 35 lbs)



11



Installing and Removing the Infant Car Seat with the Base Storing LATCH/UAS for Installations with Vehicle Belts

When using your vehicle Lap/Shoulder or Lap Belts to secure the Base in the installation sections on pgs. 43-61, the LATCH/UAS Connectors **MUST** first be securely stored in the Base. Loose Connectors could seriously injure vehicle occupants in the event of a crash or interfere with vehicle belt installation.

To store the LATCH/UAS Connectors:

1. Fully extend the LATCH/UAS Strap on each side of the Base
2. Slide each LATCH/UAS Connector back into its Storage slot until an audible **CLICK** is heard.

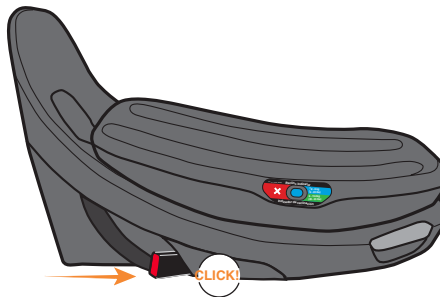

Installing and Removing the Infant Car Seat with the Base

Installing with Base Using Lap/Shoulder Belts

! WARNING! DEATH or SERIOUS INJURY can occur.

NEVER install this Child Restraint using a non-locking vehicle Lap/Shoulder Belt. A locking clip must be used with a vehicle belt that **DOES NOT LOCK**. Call ParentLink Customer Service at 1-877-242-5676 to obtain a locking clip.

1. Ensure that LATCH/UAS Connectors are in the storage position (see pg. 42).
2. Make sure the vehicle is on level ground and place the Base in an approved vehicle seating location.
3. Rotate Adapter to Boarding Position and push button on Belt Tensioner Handle and pull open.

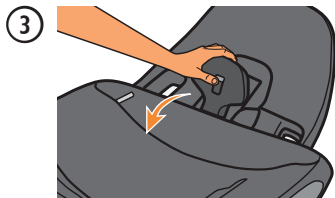
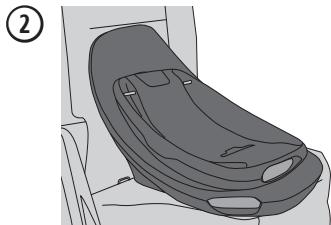

Installing and Removing the Infant Car Seat with the Base

Installing with Base Using Lap/Shoulder Belts

4. Route both vehicle belts through Belt Path Opening, under SafeLock along Belt Path, and through other Belt Path Opening.
BUCKLE THE BELT. Make sure the belts lie flat and are not twisted.

The vehicle belt should **ALWAYS** be routed **UNDER** the Safelock Belt Tensioner. **NEVER** place a vehicle belt over the Safelock Belt Tensioner, even in a vehicle with longer Buckle Stalks.

NOTE: Make sure that vehicle belt buckle and hardware do not interfere with correct installation of the Base and/or the rotation/recline of the Adapter.

5. On the Buckle side, first lift up on the Shoulder Belt to remove slack in the Lap Belt. Then remove slack from the Shoulder Belt on the opposite side.

Remove slack from the vehicle belts, being careful not to overtighten. The SafeLock Belt Tensioner will tighten the system fully.

4



5



Installing and Removing the Infant Car Seat with the Base

Installing with Base Using Lap/Shoulder Belts

6. Press down on the sides of the SafeLock Belt Tensioner until an audible **CLICK** is heard. If Belt Tensioner does not lock, try loosening the vehicle belt slightly, then try to close again.



7. Grab the Base at the Belt Path and pull from side to side and front to back to make sure it is installed correctly. The Base should not move more than 2.5 cm (1 in) in any direction.

If the Base moves too much, open the SafeLock Belt Tensioner and remove a little more slack from the vehicle belt, then close and recheck. After this, if the Base still moves too much, you may need to try a different vehicle seat location or installation method, or both.

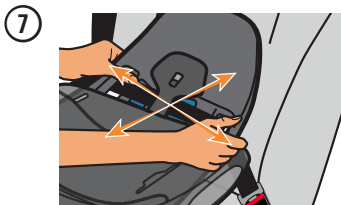

Installing and Removing the Infant Car Seat with the Base

Installing with Base Using Lap/Shoulder Belts

- Put vehicle belt in locked mode (see vehicle owner's manual for more information). In most vehicles, you can switch the Shoulder Belt Retractor into locking mode by pulling out Shoulder Belt all the way and then letting it rewind into the retractor. Pull on the belt to make sure it is locking.
- Place the Infant Car Seat into the Base, and listen for a **CLICK**. Check that the Car Seat is installed by lifting up on the Handle (see pg. 34).

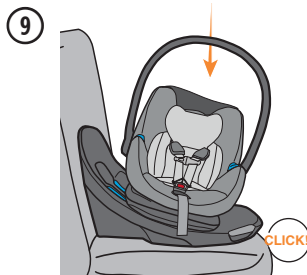

Installing and Removing the Infant Car Seat with the Base

Installing with Base Using Lap/Shoulder Belts

10. Rotate Base to Drive Position (see pgs. 32-33).

NOTE: This Child Restraint is allowed to touch the vehicle seat in front of it as long as the recline angle of the Child Restraint is not affected.

10

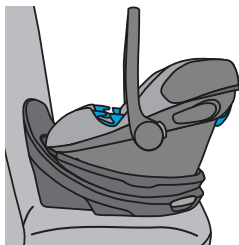

11. Adjust the Adapter recline angle (see pg. 35) to achieve the correct angle for your child's weight as shown on the Level Indicator below.

- **BLUE** zone:
1.8 - 9 kg
(4 - 20 lbs)
- **GREEN** zone:
9 - 15.8 kg
(20 - 35 lbs)



11

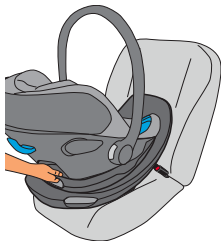

Installing and Removing the Infant Car Seat with the Base

Installing with Base Using Lap Belt Only

1. Ensure that LATCH/UAS Connectors are in the storage position (see pg. 42).
2. Make sure the vehicle is on level ground and place the Base in an approved vehicle seating location.
3. Rotate Adapter to Boarding Position and push button on Belt Tensioner Handle and pull open.

②

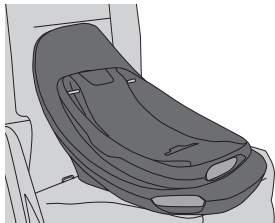

③

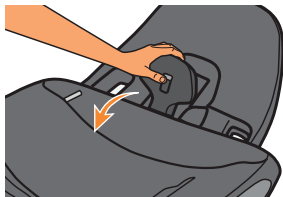

Installing and Removing the Infant Car Seat with the Base

Installing with Base Using Lap Belt Only

4. Route the vehicle Lap Belt through Belt Path Opening, under SafeLock along Belt Path, and through other Belt Path Opening. **BUCKLE THE BELT.** Make sure the Lap Belt lays flat and is not twisted.

The vehicle belt should **ALWAYS** be routed **UNDER** the Safelock Belt Tensioner. **NEVER** place a vehicle belt over the Safelock Belt Tensioner, even in a vehicle with longer Buckle Stalks.

NOTE: Make sure that vehicle belt buckle and hardware do not interfere with correct installation of the Base and/or the rotation/recline of the Adapter.

5. On the Buckle side, remove slack from the Lap Belt, being careful not to overtighten. The SafeLock Belt Tensioner will tighten the system fully.

After removing slack, secure the free end of the Lap Belt under the SafeLock Belt Tensioner.

4



5



Installing and Removing the Infant Car Seat with the Base

Installing with Base Using Lap Belt Only

6. Press down on the sides of the SafeLock Belt Tensioner until an audible **CLICK** is heard. If Belt Tensioner does not lock, try loosening the vehicle belt slightly, then try to close again.



7. Grab the Base at the Belt Path and pull from side to side and front to back to make sure it is installed correctly. The Base should not move more than 2.5 cm (1 in) in any direction.

If the Base moves too much, open the SafeLock Belt Tensioner and remove a little more slack from the vehicle belt, then close and recheck. After this, if the Base still moves too much, you may need to try a different vehicle seat location or installation method, or both.

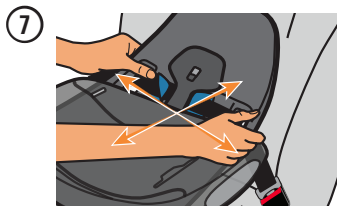

Installing and Removing the Infant Car Seat with the Base

Installing with Base Using Lap Belt Only

8. Place the Infant Car Seat into the Base, and listen for a **CLICK**. Check that the Car Seat is installed by lifting up on the Handle (see pg. 34).

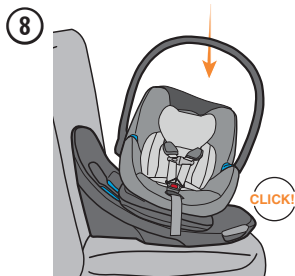

9. Rotate Base to Drive Position (see pgs. 32-33).

NOTE: This Child Restraint is allowed to touch the vehicle seat in front of it as long as the recline angle of the Child Restraint is not affected.

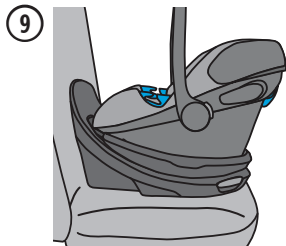

Installing and Removing the Infant Car Seat with the Base

Installing with Base Using Lap Belt Only

10. Adjust the Adapter recline angle (see pg. 35) to achieve the correct angle for your child's weight as shown on the Level Indicator below.

- **BLUE** zone:
1.8 - 9 kg
(4 - 20 lbs)
- **GREEN** zone:
9 - 15.8 kg
(20 - 35 lbs)



10

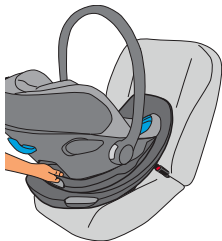

Installing and Removing the Infant Car Seat ONLY

Installing the Infant Car Seat With Lap/Shoulder Belts

! WARNING! DEATH or SERIOUS INJURY can occur.

- **NEVER** install this Child Restraint using a non-locking vehicle Lap/Shoulder Belt. A locking clip must be used with a vehicle belt that **DOES NOT LOCK**. Call ParentLink Customer Service at 1-877-242-5676 to obtain a locking clip.
- **ALWAYS** have the Handle in a **LOCKED** position while using this Child Restraint in a vehicle (see pg. 26).
- **NEVER INSTALL** the Infant Car Seat with both the Lap and Shoulder Belts routed through the Lap Belt Guides.

1. Position Infant Car Seat firmly against the back of the rear vehicle seat as shown.
2. Route only the vehicle Lap Belt through the blue **INFANT CAR SEAT LAP BELT GUIDES** and **BUCKLE THE BELT**.

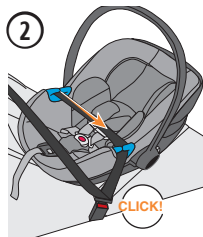
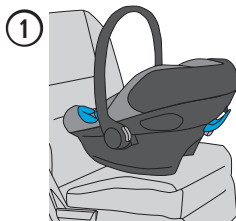

Installing and Removing the Infant Car Seat ONLY

Installing the Infant Car Seat With Lap/Shoulder Belts

3. Lift Shoulder Belt over Handle and around Infant Car Seat. Slide Shoulder Belt into the rear blue Shoulder Belt Guide.
4. Lock your vehicle Lap/Shoulder Belt. Refer to your vehicle owner's manual for how your vehicle Lap and Shoulder Belt locks.

In many vehicles, you can switch the Shoulder Belt Retractor into locking mode by pulling the Shoulder Belt out all the way. Check the vehicle owner's manual to see how your system locks.

To check if the vehicle belt is locked, after you install the Infant Car Seat, pull up firmly on the Lap Belt between the Lap Belt Guides. The belt should remain tight if the vehicle system is locked.

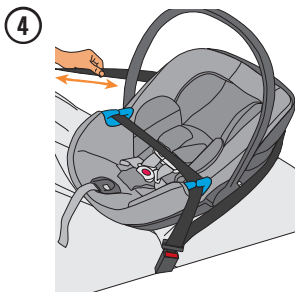
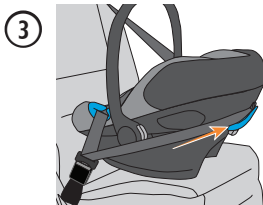

Installing and Removing the Infant Car Seat ONLY

Installing the Infant Car Seat With Lap/Shoulder Belts

5. Push Infant Car Seat firmly into vehicle seat, pressing down near the Buckle Strap between the child's legs (A) while removing slack from Lap Belt (B). Repeat for Shoulder Belt.

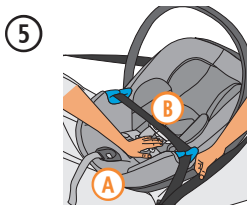

6. Check the recline angle. Adjust the seat angle until the **WHITE LEVEL LINE** on the Infant Car Seat is level with the ground. A tightly rolled towel or pool noodle (pg. 30) may be placed under the Infant Car Seat, near the vehicle seat back, to adjust the angle, if necessary.

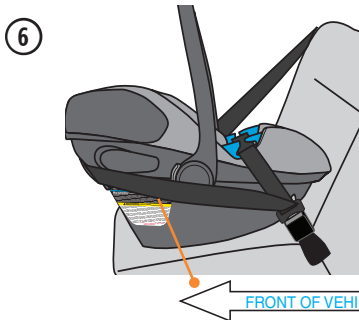

White line **MUST** be parallel to ground when seat is installed in vehicle without base

Installing and Removing the Infant Car Seat ONLY

Installing the Infant Car Seat With Lap/Shoulder Belts

- Grab the Infant Car Seat at the Belt Guides and pull from side to side and front to back to make sure it is installed correctly. The Infant Car Seat should not move more than 2.5 cm (1 in) in any direction.

If the Infant Car Seat moves too much, tighten the vehicle belts more and recheck. You may try a different vehicle seat or installation method, or both.

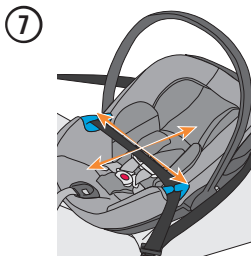

Installing and Removing the Infant Car Seat ONLY

Installing the Infant Car Seat With Lap/Shoulder Belts (Alternate)

Use this alternate installation method only when the preferred method found on pages 53-56 does not work with your vehicle Lap and Shoulder belts.

! WARNING! DEATH or SERIOUS INJURY can occur.

- **NEVER** install this Child Restraint using a non-locking vehicle Lap/Shoulder Belt. A locking clip must be used with a vehicle belt that **DOES NOT LOCK**. Call ParentLink Customer Service at 1-877-242-5676 to obtain a locking clip.
- **ALWAYS** have the Handle in a **LOCKED** position while using this Child Restraint in a vehicle (see pg. 26).
- **NEVER INSTALL** the Infant Car Seat with both the Lap and Shoulder Belts routed through the Lap Belt Guides.

1. Position Infant Car Seat firmly against the back of the rear vehicle seat as shown.
2. Route only the vehicle Lap Belt through the blue **INFANT CAR SEAT LAP BELT GUIDES** and **BUCKLE THE BELT**. Route the **SHOULDER PORTION** diagonally across the vehicle seat back as shown.

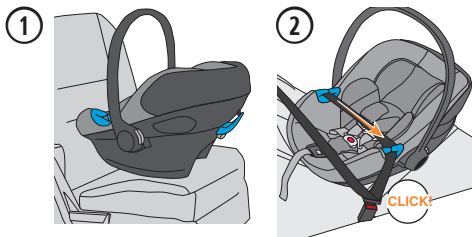

Installing and Removing the Infant Car Seat ONLY

Installing the Infant Car Seat With Lap/Shoulder Belts (Alternate)

3. **LOCK** your vehicle lap Shoulder Belt. Refer to your vehicle owner's manual for how your vehicle Lap and Shoulder Belt locks.

In many vehicles, you can switch the Shoulder Belt Retractor into locking mode by pulling the Shoulder Belt out all the way. Check the vehicle owner's manual to see how your system locks.

To check if the vehicle belt is locked, after you install the Infant Car Seat, pull up firmly on the Lap Belt between the Belt Guides. The belt should remain tight if the vehicle system is locked.

4. Push Infant Car Seat firmly into vehicle seat, pressing down near the Buckle Strap between the child's legs, while removing slack from Lap Belt (A). Repeat for Shoulder Belt (B).

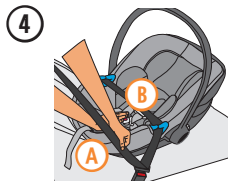
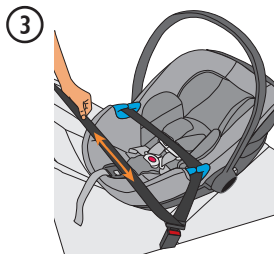

Installing and Removing the Infant Car Seat ONLY

Installing the Infant Car Seat With Lap/Shoulder Belts (Alternate)

5. Check the recline angle. Adjust the seat angle until the **WHITE LEVEL LINE** on the Infant Car Seat is level with the ground. A tightly rolled towel or pool noodle (pg. 30) may be placed under the Infant Car Seat, near the vehicle seat back to adjust the angle, if necessary.

5

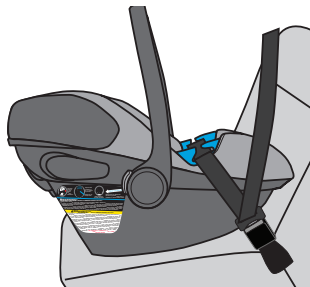

6. Grab the Infant Car Seat at the Belt Guides and pull from side to side and front to back to make sure it is installed correctly. The Infant Car Seat should not move more than 2.5 cm (1 in) in any direction.

If the Infant Car Seat moves too much, tighten the vehicle belts more and recheck. You may try a different vehicle seat or installation method, or both.

6

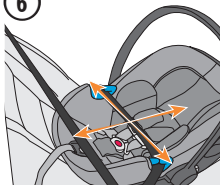

White line **MUST** be parallel to ground when seat is installed in vehicle without base

Installing and Removing the Infant Car Seat ONLY

Installing the Infant Car Seat With Lap Belt Only

! WARNING! DEATH or **SERIOUS INJURY** can occur.

ALWAYS have the Handle in a **LOCKED** position while using this Child Restraint in a vehicle (see pg. 26).

1. Position Infant Car Seat firmly against the back of the rear vehicle seat as shown.
2. Route vehicle Lap Belt through the blue **INFANT CAR SEAT LAP BELT GUIDES** and **BUCKLE THE BELT.**
3. Push Infant Car Seat firmly into vehicle seat, pressing down near the Buckle Strap between the child's legs, while removing slack from the Lap Belt. If necessary, tuck the loose end of the Lap Belt out of the way.

①

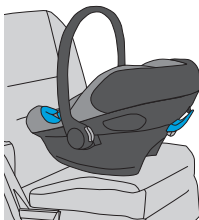

②

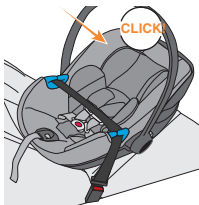

Installing and Removing the Infant Car Seat ONLY

Installing the Infant Car Seat With Lap Belt Only

4. Check the recline angle. Adjust the seat angle until the **WHITE LEVEL LINE** on the Infant Car Seat is level with the ground. A tightly rolled towel or pool noodle (pg. 30) may be placed under the Infant Car Seat near the vehicle seat back to adjust the angle.

④

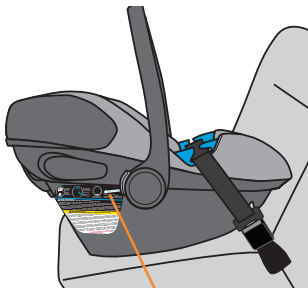

5. Grab the Infant Car Seat at the Belt Guides and pull from side to side and front to back to make sure it is installed correctly. The Infant Car Seat should not move more than 2.5 cm (1 in) in any direction.

If the Infant Car Seat moves too much, tighten the vehicle belts more and recheck. You may try a different vehicle seat or installation method, or both.

⑤

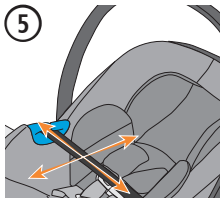

White line **MUST** be parallel to ground when seat is installed in vehicle without base

Securing the Child

! WARNING! DEATH or SERIOUS INJURY can occur.

- **ALWAYS** check the Harness Buckle to make sure it is securely latched. Failure to fasten and tighten the Harness system correctly with each use can result in **DEATH** or **SERIOUS INJURY**.
- **DO NOT** use Child Restraint if Buckle Tongues **DO NOT** click into the Buckle. Please call ParentLink Customer Service before using the Child Restraint.
- In cold weather, **DO NOT** dress the child in bulky clothing like snowsuits when riding in a Car Seat. Bulky clothing makes it difficult to properly tighten the Harness to the child, which may allow the child to be ejected from the Restraint during a crash. If necessary, place a blanket over the harnessed child without interfering with the Harness system.

1. Loosen Harness by firmly pressing down on the Harness Adjustment Button (A) while pulling forward on both straps at shoulder level (B).
2. Press red button on Harness Buckle to release Tongues.
3. Separate Chest Clip and hook the Harness Buckle Tongues over the Lap Belt Guides to allow for easier placement of child in the seat.

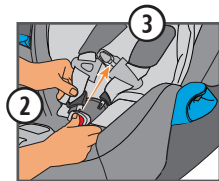
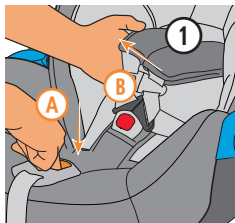

Securing the Child

- Place child in Infant Car Seat in seated position, making sure there are no gaps beneath or behind the child and their back is fully supported.
- Pull Harness Straps over each arm onto shoulders and around the hips. Make sure Buckle Pad and Harness Buckle are between the legs.

IMPORTANT:

- MAKE SURE** Harness Straps are **AT OR JUST BELOW** child's shoulders.
 - The Buckle Strap should **ALWAYS** be as close as possible to, but **NEVER** under, the child. Adjust the Buckle Strap as shown on pgs. 66-67.
- Adjust the Headrest (see pg. 29).
 - Buckle by inserting one Tongue at a time into the Harness Buckle, listening for an audible **CLICK** with each one. Make sure Harness Straps are not twisted.

5

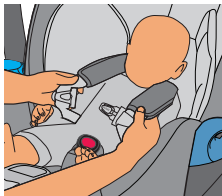

6

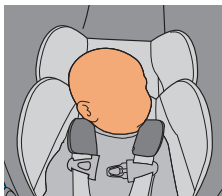

7

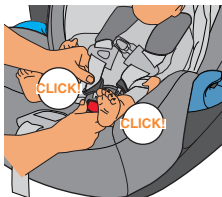

Securing the Child

8. Connect the Chest Clip listening for an audible **CLICK**.

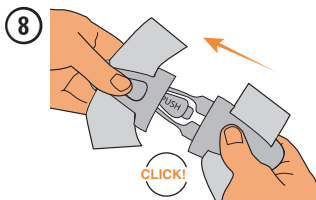

9. Pull up on Harness Straps to snug around the child's hips while holding the Chest Clip in place.

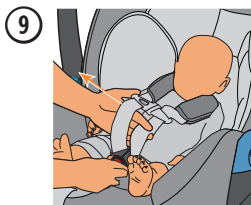

10. Slowly pull the Adjuster Strap to tighten the Shoulder Straps. A snug strap should not allow any slack. It lies in a relatively straight line without sagging. It does not press on the child's flesh or push the child's body into an unnatural position.

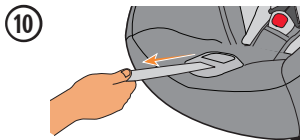

Securing the Child

11. Position the center of the Chest Clip even with the child's armpits. Make sure the Shoulder Pads do not interfere with the placement of the Chest Clip.

NOTE: If the Shoulder Pads don't allow a proper fit, they can be removed to provide more space for the Chest Clip. Unsnap to remove.

12. To test for a properly tightened Harness, pinch the Shoulder Strap. A snug Harness should not allow you to pinch any slack when pinched between your thumb and forefinger. If needed, pull Adjuster Strap further for a tight and proper fit.

13. Be sure to recheck the recline angle (pg. 31) with the child secured in place. If Recline Angle is not correct after installation:

- Readjust using Recline Adjustment Handle, **or**
- Use a tightly rolled towel or pool noodle under the Base, near the vehicle seat back, as shown at right.

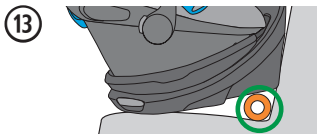
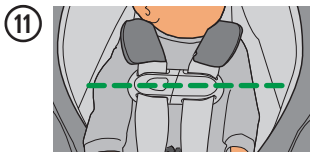

Changing the Buckle Strap Position

As your child grows, you will need to change the Buckle Strap position so that it is in the slot closest to your child. The Buckle Strap should **ALWAYS** be as close as possible to, but **NEVER** under, the child.

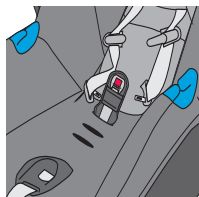

Rear Slot

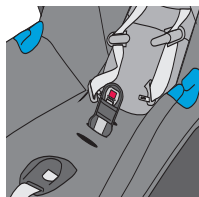

Middle Slot

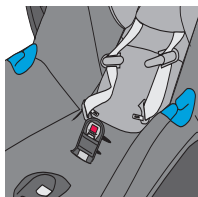

Front Slot

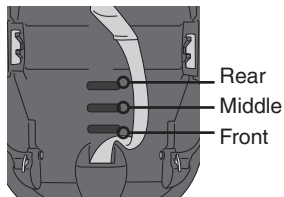

Bottom View

NOTE: To improve Harness fit for Premature and Smaller Infants, see page 11 for an additional Buckle Strap option.

! WARNING! DEATH or SERIOUS INJURY can occur.



If there is still a gap between the child and the Buckle Strap when the Buckle Strap is in the slot closest to, but **NEVER** under, the child, place a tightly rolled washcloth between the child and the Buckle Strap to prevent the child from slouching or sliding down into the Buckle Strap.

Changing the Buckle Strap Position

1. To reposition Buckle Strap, loosen Harness Straps and hook Harness Buckle Tongues over Lap Belt Guides to get them out of the way.

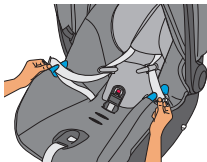

2. Remove Buckle Strap Anchor from its position at bottom of Carrier and push up through slot to top of seat.

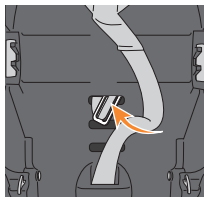

3. Insert Buckle Strap Anchor and Harness Buckle Cover into slot that is closest to, but **NEVER** under, the child. Ensure that Buckle Strap Anchor feeds through Seat Cover into corresponding slot in Seat Shell.

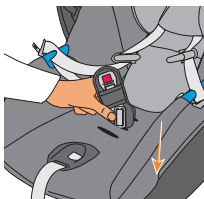

4. Make sure Buckle Strap Anchor is completely through slot and is lying flat against bottom of seat.



5. Pull up on Buckle Strap **A** to make sure it is securely fastened.

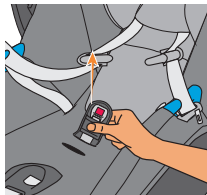

Ensure that end of Harness Buckle Cover is positioned towards back of seat as shown **B**.

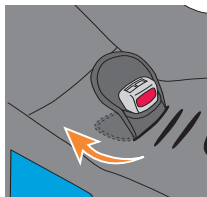

Using the Infant Car Seat on Aircraft

! WARNING! DEATH or SERIOUS INJURY can occur.

- The FAA recommends that children up to 18 kg (40 lbs) use a certified, harnessed child seat while traveling on an airplane. The ATON G SWIVEL is certified for aircraft use if used **WITHOUT** the Base.
- **ALWAYS** have the Handle in a **LOCKED** position while using this Child Restraint in an aircraft (see pg. 26).
- **DO NOT** use the Convenience Base when installing Child Restraint in aircraft. Remember to gate check your Base or check it in as luggage if you plan to use it at your destination and **ALWAYS** inspect for damage before use.



1. Ensure that the aircraft seat is in a fully upright position.
2. Position Infant Car Seat **REAR-FACING** in aircraft seat with the foot end firmly against the back of the aircraft seat.
IMPORTANT: Install your Infant Car Seat in a window seat to avoid blocking the aisle.
3. Route Lap Belt through both Lap Belt Guides and **BUCKLE THE BELT.**

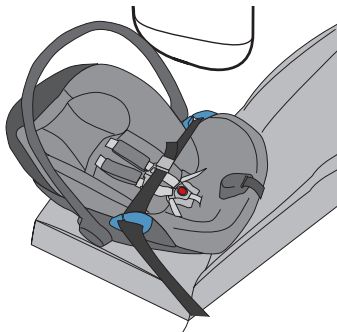

Using the Infant Car Seat on Aircraft

NOTE: The aircraft seat belt must be as tight as possible. Using your full weight, push the Infant Car Seat firmly into the aircraft seat while pulling on the excess seat belt strap to tighten, then route the excess seat belt strap back through the belt slots.

4. Check the recline angle. Adjust the seat angle **UNTIL THE WHITE LEVEL LINE ON THE INFANT CAR SEAT IS LEVEL WITH THE FLOOR OF THE AIRCRAFT.**

NOTE: A tightly rolled airline blanket may be placed under the Infant Car Seat, near the aircraft seat back (as indicated by the green circle), to adjust the angle. In some instances you may not have enough space to fully recline the Infant Car Seat.

5. Grab the Infant Car Seat at the Belt Guides and pull from side to side and front to back to make sure it is installed correctly. The Infant Car Seat should not move more than 2.5 cm (1 in) in any direction.

If the Infant Car Seat moves too much, tighten the airplane belts more and recheck.

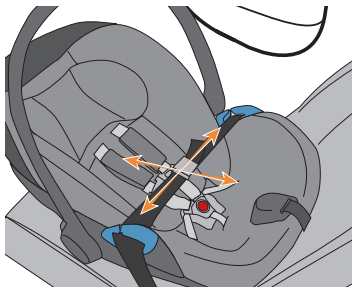
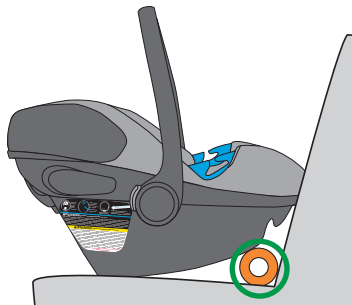

Removing and Replacing Seat Cover

! WARNING! DEATH or SERIOUS INJURY can occur.

- The integrated No Rethread Harness System cannot be removed from the seat. **NEVER** remove or attempt to remove parts of the Harness System.
 - **DO NOT** damage, remove or dispose of any EPS foam.
 - **NEVER** use Infant Car Seat without properly installed Seat Cover.
-

Removing Seat Cover

1. Disconnect Harness Buckle and Chest Clip (see pgs. 26-27).
2. Unsnap the two Shoulder Pads from the Harness.

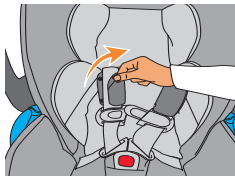
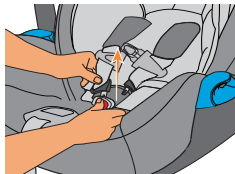

Removing and Replacing Seat Cover

3. If using the Infant Insert, simply remove it from the Harness Straps.

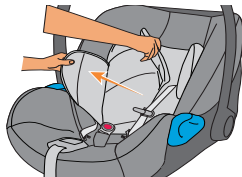

4. Pull Headrest Cover forward and unsnap the two snaps to remove it from the Harness.

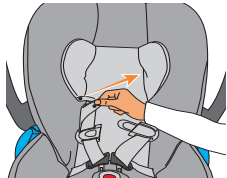

5. Unsnap the two snaps holding the Canopy fabric and push Canopy forward.

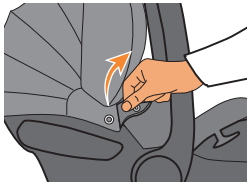

Removing and Replacing Seat Cover

6. Remove the Canopy fabric, then lift the Seat Cover from the top of the plastic shell.

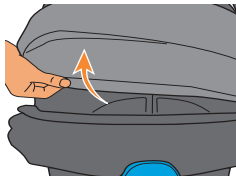

7. Unsnap two dual action snaps at side of Carrier.



8. Remove Buckle Strap Anchor from its position at bottom of Carrier and push up through slot to top of seat (A), then remove Harness Buckle and Harness Buckle Cover (B).

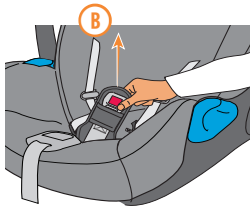
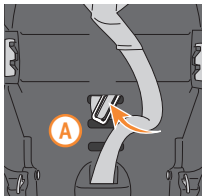

Removing and Replacing Seat Cover

9. Unsnap the four snaps at the inside center of the Seat Cover.

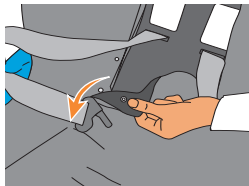

10. Pull the Seat Cover away from the Harness Adjuster and Belt Guides, and lift the Seat Cover off the shell.



Installing Seat Cover

1. Install the Seat Cover onto the Infant Car Seat, being sure to pull it over the Belt Guides and Harness Adjuster.



Removing and Replacing Seat Cover

2. With Harness Buckle installed into Harness Buckle Cover (A), insert through appropriate slot in Seat Cover (B) and corresponding slot in Seat Shell (see pg. 67).

Ensure that end of Harness Buckle Cover is positioned towards back of seat as shown (C).

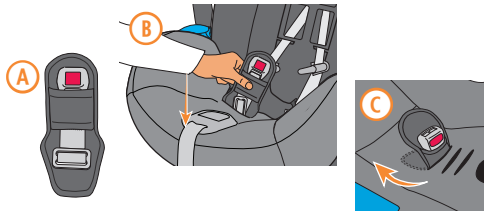

3. Snap the four snaps at the inside center of the Seat Cover.

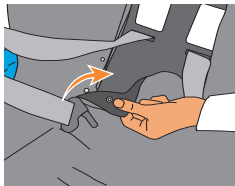

4. Snap two dual action snaps at side of Carrier.



Removing and Replacing Seat Cover

5. Attach the Seat Cover to the top of the plastic shell, then replace the Canopy fabric.

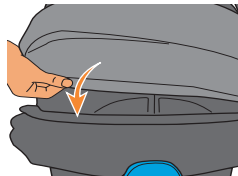

6. With the Canopy fully extended, snap the two snaps holding the Canopy fabric in place.

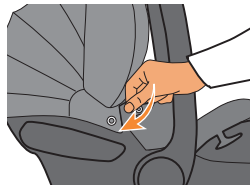

7. Replace the Headrest Cover and snap the two snaps to attach it to the Harness.

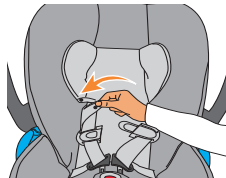

Removing and Replacing Seat Cover

8. Reattach Infant Insert to Harness if used.

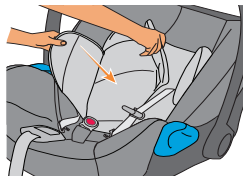

9. Reattach two Shoulder Pads to Harness.

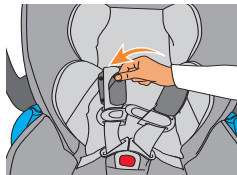

10. Reconnect Harness Buckle and Chest Clip (see pgs. 26-27), making sure that the Harness lies flat and is not twisted.

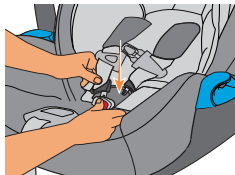

Care and Cleaning

IMPORTANT: NEVER use bleach, household cleaners, or solvents. **DO NOT** use lubricants of any kind.

Seat Cover, Shoulder Pads, Infant Insert, and Buckle Cover

- Spot clean as needed with a clean cloth using mild detergent and water.
- Machine wash in cold water on delicate cycle.
- Air dry. **DO NOT** iron.

Harness Straps and Buckle Strap

Sponge clean using warm water and mild soap. Air dry. **DO NOT** iron.

Harness Buckle and LATCH/UAS Connectors

- Spot clean as needed with mild detergent and warm water.
- Allow to air dry thoroughly.
- Test by fastening and unfastening until an audible **CLICK** is heard. If there is no **CLICK**, repeat the cleaning procedure.

Plastic and Metal Parts

Wipe clean with mild detergent and warm water.

Safety Checklist

- Did you read and understand the vehicle owner's manual, this Owner's Manual, and all labels found on this Child Restraint?
 - Is the Child Restraint rear facing in an approved vehicle seat location?
 - If using the ATON G SWIVEL Base, is the Base secured to the vehicle seat? Is the Infant Car Seat securely attached to the Base?
 - Is the ATON G SWIVEL turned to the Drive Position?
 - If using the ATON G Infant Car Seat Only, is the Infant Car Seat secured to the vehicle seat?
 - Is the seat recline angle correct according to the Level Indicator or **WHITE LEVEL LINE**?
 - Is the No Rethread Harness adjusted to the correct position for the size of the baby with the Harness Slots at or below your child's shoulders?
 - Is the Harness snug around the baby and secured properly with the Chest Clip positioned at armpit level?
 - Is Buckle Strap snug against the child but NOT under the child?
 - Is the Handle LOCKED while using this Child Restraint in a vehicle?
 - Does your child weigh between 1.8 and 15.8 kg (4 and 35 lbs)?
 - Is your child between 43 and 81 cm (17 and 32 in) in height?
 - Is the top of your child's head more than 2.5 cm (1 in) from the top of the Infant Car Seat or Headrest, whichever is higher?
 - Is today's date before the "Expires On" date on the Child Restraint and Base?
 - Did you check for hot surfaces?
- If you answered YES to all of these questions, you are good to go, and please **DRIVE SAFELY!**

Resources

Installation Help

Installing your Child Restraint correctly in your vehicle is extremely important for your child's safety. However, it is not always easy to do. **Statistics show that over 75% of Child Restraints are being used incorrectly!**

Please contact ParentLink Customer Service, where we have many Child Passenger Safety (CPS) Technicians on staff, with any questions you may have concerning installation, parts, maintenance, or warranty information. If you have specific questions, e-mail us a picture. It will help us serve you better.

When you contact us, please have the Model Number and Manufactured on Date ready so that we may help you efficiently. This information can be found on the registration card or on the underside of your Infant Car Seat and Base.

Please contact the U.S. CYBEX Distributor, Columbus Trading-Partners USA, Inc.

- Toll free: 1-877-242-5676
- E-mail: info.us@cybex-online.com
- Web: www.cybex-online.com
- Video Appointment: <https://cybex.appointlet.com/>

Make sure your CYBEX ATON G SWIVEL is installed correctly by using:

- www.safekids.org
- www.seatcheck.org
- Your local fire and police departments for certified CPS Technicians.

Recycling: Once your seat has reached its expiration date, we recommend recycling the seat. Contact your local community recycling center for the best way to dispose of your seat. We do not recommend giving or selling the seat to anyone, or simply putting it in the garbage.

Warranty

IMPORTANT: Immediately register your ATON G SWIVEL so we can contact you in the unlikely event of a safety recall. Register online at <http://register.cybex-online.com/us/carseats> or mail in the separate registration card provided.

LIMITED WARRANTY

CYBEX warrants to the original consumer purchaser that this product will be free from defects in material and workmanship for two (2) years from the date of original purchase (the "Warranty Period"). During the Warranty Period, CYBEX, at its option, may repair or replace this product if it is found by the manufacturer to be defective in material or workmanship. CYBEX reserves the right to discontinue or change parts, fabrics, models, or products, or to substitute this product with a comparable model or product. To make a claim under this warranty, please contact us at info.us@cybex-online.com, call us at 1-877-242-5676, or write to us at:

CYBEX Warranty
Columbus Trading-Partners USA Inc.
1801 Commerce Drive
Piqua, Ohio 45356, USA

An original receipt is required to validate your warranty and shipping charges will be the responsibility of the original consumer purchaser. To expedite the processing of any future warranty claims and to verify the original date of purchase, please complete and mail the pre-addressed owner registration card within thirty (30) days of purchase.

Warranty

WARRANTY LIMITATIONS

This warranty does not cover the effects of normal wear and tear or damages resulting from negligence, modification, improper installation, accidents, misuse or abuse of this product. It is expressly agreed that the obligations of CYBEX and the original consumer purchaser's remedies under the limited warranty contained herein are exclusive and are strictly limited to the repair or replacement of the product. This limited warranty is conditional upon strict compliance with the provisions of the Owner's Manual. In no event will CYBEX or the dealer selling this product be liable to you for any damages, including incidental or consequential damages, arising out of the use or inability to use this product.

LIMITATION OF WARRANTIES AND STATE/PROVINCIAL LAW RIGHTS:

The warranty and remedies as set forth above are exclusive and in lieu of all others, oral or written, express or implied. To the extent permitted by applicable law, any implied warranties, including implied warranties of merchantability and fitness for a particular purpose, are hereby disclaimed. Some states/provinces do not allow limitations as to how long an implied warranty lasts or the exclusion or limitation of incidental or consequential damages, so the above limitations may not apply to you. This warranty gives you specific legal rights, and you may have other rights, which vary from state/province to state/province. Neither CYBEX nor the dealer selling this product has authorized any person to create for it any other warranty, obligation, or liability in connection with this product.

CYBEX Industrial Limited

Suite 1222, 12/F | Leighton Centre | 77 Leighton Road | Causeway Bay | Hong Kong
www.cybex-online.com

Distributed in the United States by Columbus Trading Partners USA Inc.
1801 Commerce Drive | Piqua, OH 45356 | USA
Tel: 1-877-242-5676 | e-mail: info.us@cybex-online.com | www.cybex-online.com

© 2023 CYBEX Industrial Limited. All rights reserved. Printed in China.
This product and its components are subject to change without notice.
Patents pending.